

CliniLever[®] CP-BS Hospital Wall Bath Set Taps w/ 180 Outlet Laminar

PRODUCT CODES:

- TCWBC150C - TCWBC80C
- TCWBJ150C - TCWBJ80C

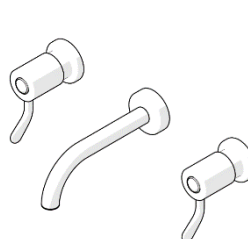

80mm Handle - SERIES

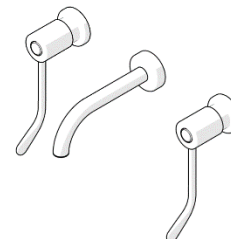

150mm Handle - SERIES

SPECIFICATIONS

- The CliniLever[®] product range is primarily used for hand washing applications in hospitals, aged care facilities, schools and in-home care.
- CliniLever[®] products provide state of the art features to comply with the latest healthcare guidelines.
- Contra rotating handles to ensure ease of use
- Laminar flow nozzle supplied standard to reduce the spread of legionella.
- Smooth round design to facilitate easy cleaning and to help reduce dirt and bacterial growth.
- Quick action SBA's includes brass jumper valve / ceramic disc component, with red and blue indicator buttons on 80mm or 150mm lever action handles.

IMPORTANT: All CliniLever[®] healthcare taps are tested in accordance with AS/NZS 3718 and leave our premises in good working order.

TECHNICAL DATA

Inlet	5/8" BSP – Male		
Outlet	Laminar Flow Aerator		
Headwork	Jumper Valve / Ceramic Disc		
Working Pressure Range (kPa)	Min	50	
	Max	500	
Working Temperature Range (°C)	Jumper Valve / Ceramic	Min	5
	Jumper Valve / Ceramic	Max	80
Nominal Flow Rate (LPM)	5.0		
Finish	Chrome		

NOTE: Galvin Engineering continually strive to improve their products. Specifications may change without notice.

TOOLS REQUIRED

- Power drill
- Spanner and hex key
- Thread tape

PRE-INSTALLATION - MOUNTING DETAILS

Wall body

- Wall body must be G5/8" FI and body should be between 0 and 15mm behind the finished wall surface.

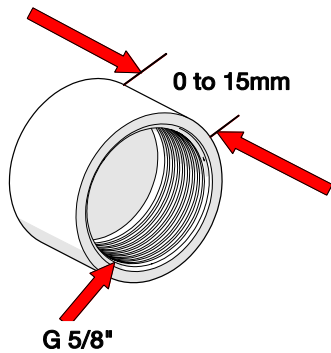

Wall spud

- Wall spud must be 1/2" BSP MI and protrude from the finished wall by no more than 15mm

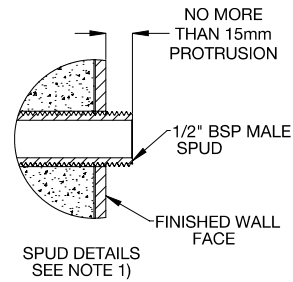

Note: In some situations, a male thread connection on the tap may be more suited. If so, please contact us on 1300 514 074

Note: Before installation, all lines must be flushed. We recommend that a line strainer be installed prior to taps to eliminate any foreign material.

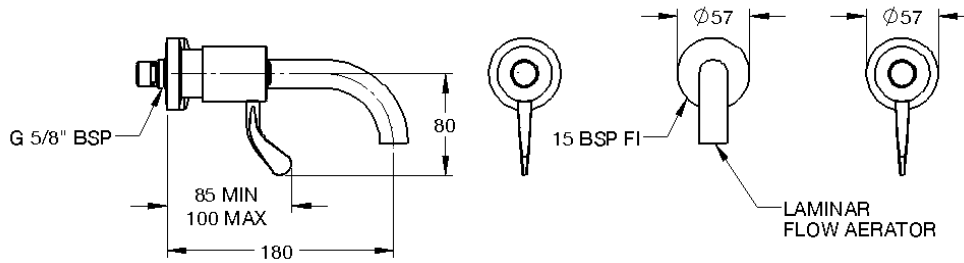

TCWBC80C/TCWBJ80C

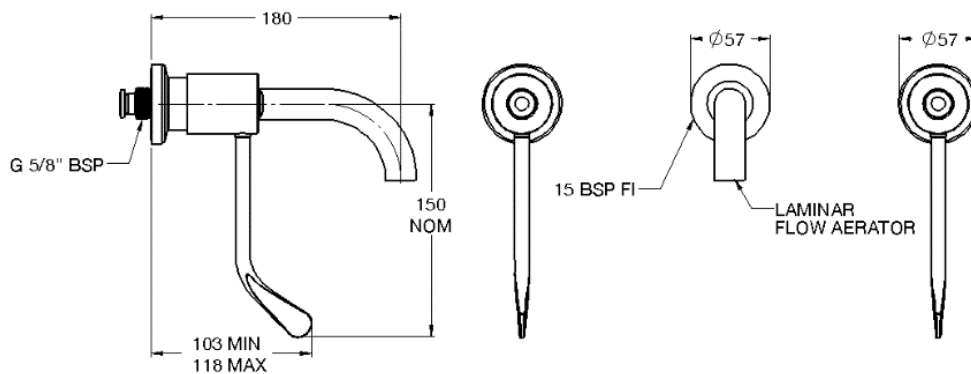

TCWBC150C/TCWBJ150C

INSTALLATION

IMPORTANT: Galvin Engineering products must be installed in accordance with these installation instructions and in accordance with AS/NZS 3500, the PCA and your local regulatory requirements. Water and/or electrical supply conditions must also comply to the applicable national and/or state standards. Failing to comply with these provisions shall void the product warranty and may affect the performance of the product.

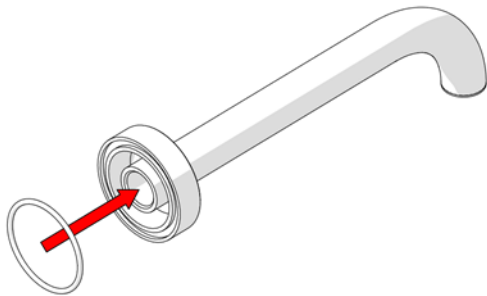

1. Fit O-ring

- Before fitting spout to wall spud, ensure the o-ring is in place as shown

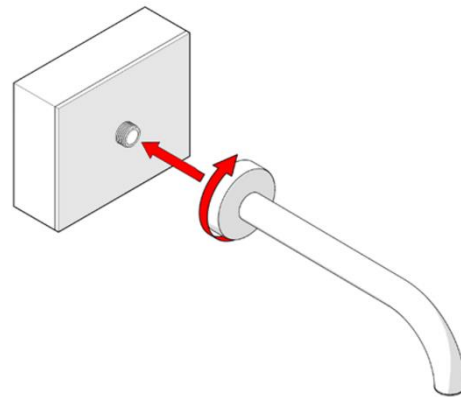

2. Fit Spout

- Screw spout clockwise onto wall spud as shown.
- Ensure thread tape is used.

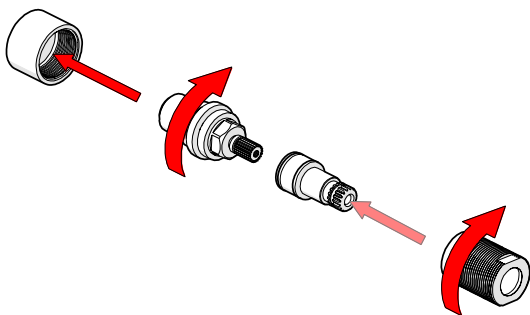

3. Fit Spindle Assembly

- Remove handle and flange from cartridge assembly. Unscrew the ¼ turn ceramic head part from the threaded sleeve assembly and screw ceramic cartridge into the valve body by hand, tighten using a 17mm spanner.
- Refit threaded sleeve and spindle.
- **The ¼ turn ceramic head part MUST be fitted into the wall body prior to refitting the threaded sleeve and spindle. DO NOT tighten cartridge by using the spindle or the threaded sleeve.**

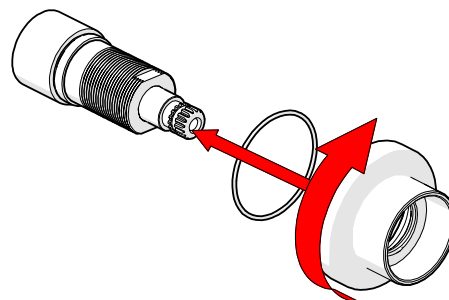

4. Fit Wall Flange

- Ensure o-ring is fitted to the bottom of the wall flange, and then hand-tighten the wall flange onto the threaded sleeve.

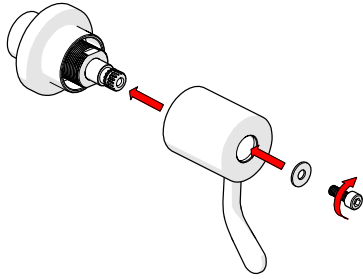

5. Fit handle

- Ensure the spindle is in the closed position and firmly press the CliniLever® lever handle onto the spindle in the desired orientation.
- Check operation of CliniLever® lever handle. They should turn freely for a full ¼ turn.
- Secure the handle in position using the supplied washer and stainless steel cap screw.

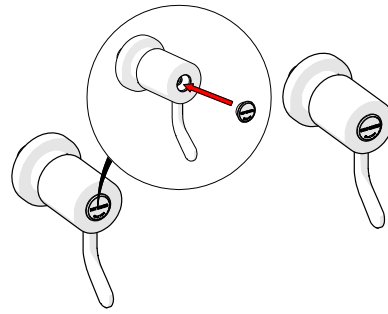

6. Fit water temperature indicator & testing

- Once CliniLever® lever handle is secure; fit the appropriate water temperature indicator.
- Once temperature indicator is fitted, check the operation of the unit and inspect for any leaks.

TROUBLESHOOTING

PROBLEM	CAUSE	RECTIFICATION
Taps are dripping water	Jumper valves are worn or damaged	Replace jumper valve
	Ceramic discs are worn or damaged	Remove and inspect SBA. Remove debris and/or replace SBA if damaged.
	Tap seat is damaged	Refurbish tap seat using a reseating tool.
Water is leaking from spindle	O-ring on jumper valve spindle is damaged or worn	Replace o-ring
Water is not flowing from tap	Water is turned off	Turn water on
	Aerator or flow regulator is blocked by debris	Remove aerator and/or flow regulator from tap and remove debris. Install an inline strainer.
	Obstruction on spout	Check if there are obstructions hindering the water flow in the spout and take it out.
Spindle is difficult to turn (jumper valve)	Build up of scale on spindle, spindle worn or o-ring has been damaged	Remove jumper valve, clean and regrease. Replace o-ring. Complete SBA may need to be replaced.
Handle is loose	Screw has come loose	Tighten handle screw
Flange does not screw down onto basin/sink surface	Tap bodies are set too far out	Re-position tap bodies and breach piece

SERVICE AND MAINTENANCE

JUMPER VALVE TAPWARE	CERAMIC DISC TAPWARE
<ol style="list-style-type: none"> 1. Turn off the water supply and turn on the tap handle to drain water from the bodies. 2. Remove the temperature indicator from the handle. 3. Remove the handle from the tap. 4. Unscrew the top assembly from the body. 5. Check the o-ring on the spindle and the jumper valve for wear and damage. Replace if required. 6. Clean the spindle and body of debris. 7. Place a new o-ring (if required) onto the spindle and re-grease with potable water approved grease. 8. Re-assemble top assembly. Follow the product installation guidelines for the relevant product to re-assembly method. 	<ol style="list-style-type: none"> 1. Turn off the water supply and turn on the tap handle to drain water from the bodies. 2. Remove the temperature indicator from the handle. 3. Remove the handle from the tap. 4. Unscrew the ceramic head part from the body. 5. Check the o-ring on the ceramic head part for wear and damage. Replace if required. 6. Clean the head part and the body of any debris. 7. Replace the cartridge and hand tighten back into the body. 8. Follow the product installation guidelines for the relevant product to re-assemble.

WARRANTY

The warranty set forth herein is given expressly and is the only warranty given by the Galvin Engineering Pty Ltd. With respect to the product, Galvin Engineering Pty Ltd makes no other warranties, express or implied. Galvin Engineering Pty. Ltd. hereby specifically disclaims all other warranties, express or implied, including but not limited to the implied warranties of merchantability and fitness for a particular purpose.

Galvin Engineering Pty Ltd products are covered under our manufacturer’s warranty available for download from www.galvinengineering.com.au Galvin Engineering Pty Ltd expressly warrants that the product is free from operational defects in workmanship and materials for the warranty period as shown on the schedule in the manufacturer’s warranty. During the warranty period, Galvin Engineering will replace or repair any defective products manufactured by Galvin Engineering without charge, so long as the terms of the Manufacturer’s warranty are complied with.

The remedy described in the first paragraph of this warranty shall constitute the sole and exclusive remedy for breach of warranty, and Galvin Engineering Pty Ltd shall not be responsible for any incidental, special or consequential damages, including without limitation, lost profits or the cost of repairing or replacing other property which is damaged if this product does not work properly, other costs resulting from labour charges, delays, vandalism, negligence, fouling caused by foreign material, damage from adverse water conditions, chemical, electrical or any other circumstances over which Galvin Engineering has no control. This warranty shall be invalidated by any abuse, misuse, misapplication, improper installation or improper maintenance or alteration of the product.